

# Design And Implementation Of Greenhouse Automation And Monitoring System Using Iot

I.Lakshmi

Assistant Professor,  
Department of Computer Science,  
Stella Maris college,  
Chennai-600086

**Abstract:** In later situation of climate alter and its impact on the environment has propelled the ranchers to introduce nurseries in their areas. But keeping up a nursery and its manor is exceptionally work seriously and larger parts of them perform imperative operations naturally. Moreover rural analysts are confronting deficiency of great quality of information which is significant for edit advancement. In this way we have created such a taken a toll viable framework utilizing Web of Things (IoT) innovation which is centred on understanding these specific issues, our framework mechanizes the nursery upkeep operations and screen the development conditions interior the nursery closely

**Keywords:** IoT; Agriculture; Automation; Monitoring; cost effective

## I. INTRODUCTION

### A. Internet of Things (IoT)

IERC(European Investigate Cluster on the Web of Things) characterizes Web of Things as a worldwide framework for the data society, empowering progressed administrations by interconnection (physical and virtual) things based on existing and advancing interoperable data and communication technologies[1]. It could be a concept and a worldview that considers omnipresent nearness of assortment of things or objects which are associated through wired or remote communication systems and are able to interact, cooperate and communicate with each other within the environment with negligible or without any human mediation, this concepts Revolutionizes client encounters and producers' understanding of client necessities and their generation strategies; which in turn will revolutionize our way of life as a entire. Essentially it recommends that essentially each things right from a ordinary indoor regulator to a tremendous gathering line on a production line floor can be associated to the web and can be changed over into computers which can have a positive impact on their effectiveness.

### B. IoT in Agriculture

Exceptionally frequently agriculturist or Agriculturists depend upon their intestine to figure out the crucial operations which can have an unfavorable impact on their generation, here sensor information within the areas or within the nursery can

offer assistance ranchers arrange an ideal time to carry out the harvesting would at that point guarantee that the edit is prepared and the esteem created is maximized. In this way farming is one of the biggest utilize cases of IoT, other than this particular Water system, animals checking, inaccessible hardware operation and observing, prescient analytics for crops and animals, etc. are other use-cases where IoT is most helpful.[2][3][4].

## II. LITERATURE REVIEW AND SURVEY

The more current situation of diminishing water tables, evaporating of waterways and tanks, flighty condition exhibits an earnest requirement for legitimate usage of water. To adapt up to this utilization of temperature and dampness sensor at appropriate areas for checking of products is actualized in. [5]. We additionally visited couple of nurseries and watched and recorded the working strategies for the designers, which gave me a reasonable thought how the support and checking activities.[2] proposed the procedures for choice hardware,[6] gave essentials and reference models on which an IoT framework can be based and created. Similar investigation of some current frameworks gave bits of knowledge gives our first hub to begin, officially accessible frameworks in IoT-controlled cultivating and farming, as Plantlink[7], Bitponics[8], and Harvest Geek[9] are either not accessible in India or are expensive which include an impressive creation cost overhead on the yields or Agro-based items.

**TABLE 1. COMPARISON BETWEEN CURRENT SYSTEMS [10]**

Systems	Parameters Measured	Additional features	Pricing
Plantlink	Soil Moisture	Plant-Specific Algorithms, Custom Alerts, Remote Monitoring	Nearly \$69 per plant
Bitponics	Depends upon system connected	Growth plan and season specification, Analytics, multiple device support	Nearly \$9 per plant per month, \$499 for hardware
Harvest Geek	Depends on Bot Kits.	Bot Kits which makes it easier to install and modify	Not yet decided

### III. SYSTEM OVERVIEW

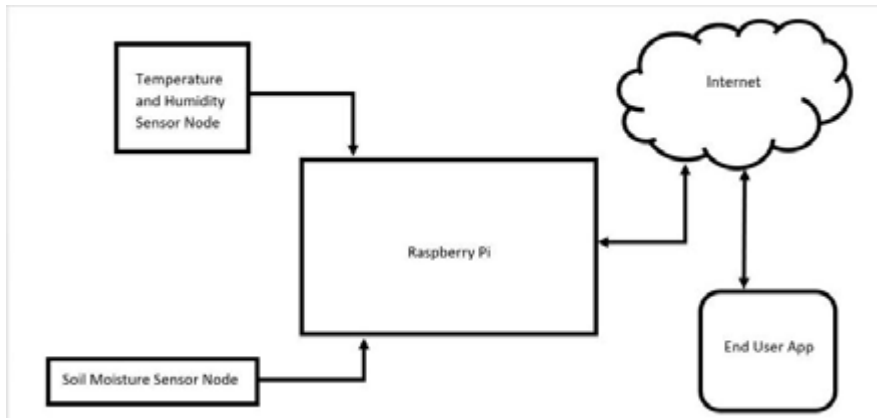

Figure 1. System Overview

The framework comprises of three segments; temperature and mugginess sensor hub, soil dampness sensor hub, and PC or versatile app to control framework. Within the show framework, each segment is associated to raspberry pi straightforwardly or in a roundabout way (by means of the Web). They are interconnected to one central server (raspberry pi). The server sends and gets data from client conclusion utilizing web network. There are three modes of operation of the framework; time-based mode, sensor based mode, and manual mode. In a time based and sensor based mode, the framework makes calculative choices based on the ranch particular conditions and controls the incitation activities though in manual mode the client can control the operations utilizing an android app or a desktop application.

This hub faculties the temperature and stickiness interior the nursery employing a pyroelectric film for temperature and a hygrometer which could be a Resistive sort stickiness sensor [11] that choose up changes within the resistance esteem of the sensor component in reaction in reaction to the alter within the stickiness. The changes recorded by both are sent to a common ADC framework which can change over the analog form of data to computerized frame which is simple to interpret and reasonable by the server. For our framework we have utilize DHT 11 sensor which could be a composite sensor containing a calibrated computerized flag yield of the temperature and stickiness, it works on the moo control input, and is exceedingly solid because it can be worked within the temperatures till 50oC and stickiness till 80% RH.

### IV. HARDWARE ARCHITECTURE OF THE SYSTEM

#### A. Temperature and Humidity Sensor Node

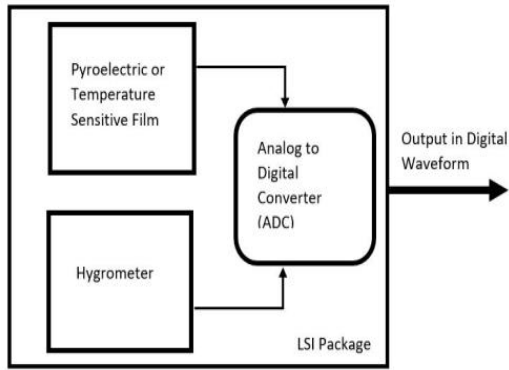

Figure 2. Temperature and Humidity Sensor Node

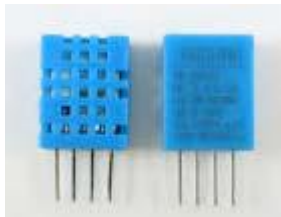

Figure 3. DHT 11 Sensor

**B. Soil Moisture Sensor Node**

The hub faculties the dampness substance based on capacitive impact, it comprises of a hygroscopic dielectric fabric sandwiched between a combine of terminals shaping a little capacitor, in our case, it is the soil acting as a dielectric fabric. The dielectric consistent of the hygroscopic dielectric fabric and the sensor geometry decide the esteem of capacitance in nonattendance of dampness, at balance conditions, the sum of dampness display depends on both the encompassing temperature and the encompassing water vapor weight. At typical room temperature, the dielectric steady of water vapor contains a esteem of approximately 80, which is much bigger than the consistent of the sensor dielectric fabric, subsequently, retention of water vapor by the sensor comes about in an increase in sensor capacitance. By definition, dampness substance could be a work of both the encompassing temperature and water vapor weight. Hence there's a relationship between dampness substance, the sum of moisture show within the sensor, and sensor capacitance. This relationship oversees the operation of this node[11].

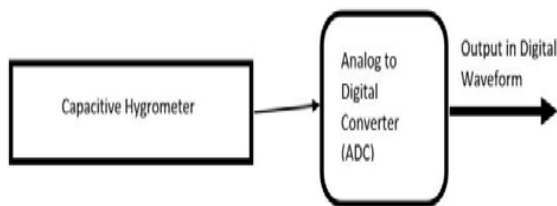

Figure 4. Soil Moisture Sensor Node

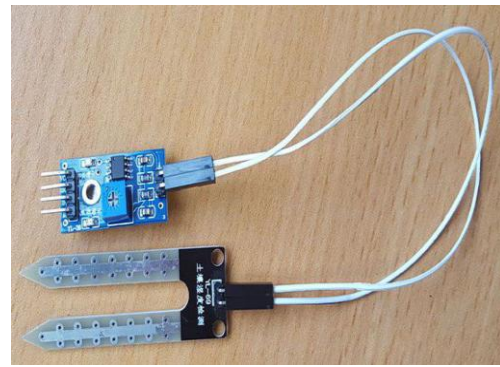

Figure 5. Capacitive Soil Moisture Sensor

**C. Raspberry Pi**

Raspberry Pi is credit card measure low-cost, tall execution computer, which is created within the Joined together Kingdom by the Raspberry Pi Establishment, we have utilized the demonstrate B of the third era of raspberry pi which is appeared in over figure. The essential reason to utilize this specific show its bolster for remote network, this show bolsters 2.4 GHz WiFi 802.11n (150 Mbit/s) and Bluetooth 4.1 (24 Mbit/s) based on Broadcom BCM43438 FullMAC chip. It too has 10/100 Ethernet harbour. With its 40 GPIO (Common Reason I/O) pins fringe meddle gets to be less cumbersome[12].

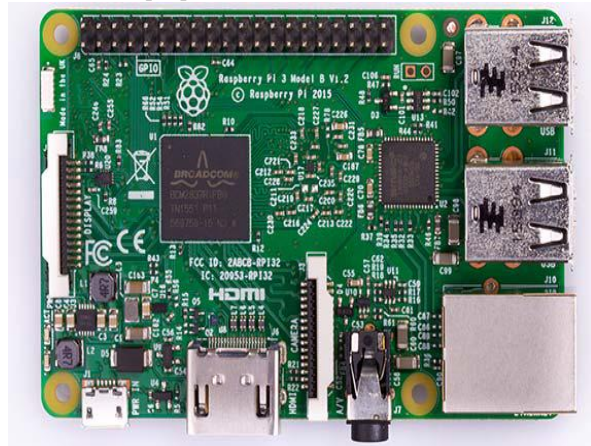

Figure 6. Raspberry Pi 3 Model B V. SOFTWARE DESIGN OF A SYSTEM

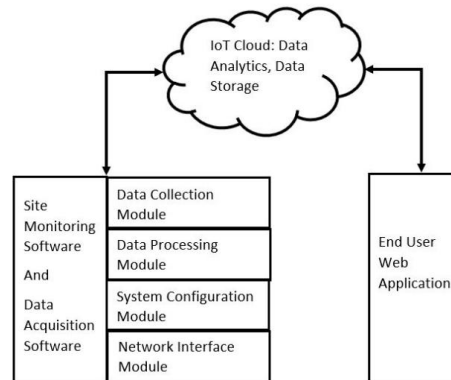

Figure 7. Software Design Overview

The Above figure portrays the review of our product structure. It comprises of Site checking and Data

procurement programming, IoT Cloud (containing Data examination and capacity and End client web application.

**A. Information Collection Module**

This module gathers and deciphers the computerized signs contribution from the sensor hubs and concentrates the usable information.

**B. Information Processing Module**

This module pre-forms the usable information for investigation to be finished. Likewise, it utilizes this information for activation purposes in timing and sensor based modes.

**C. Framework Configuration Module**

This module is utilized to design the framework essentially to set limit esteems and pre-handling calibrating.

**D. IoT Cloud**

Being an IoT framework on location we can't stack asset serious the examination code in the server in this manner utilizing IoT cloud we can perform investigation and store the information gathered for sometime later effortlessly and productively.

**E. End User Web Application**

These will the UI of the framework, this module will contain a control board where the client can watch and control the framework effectively. For building up our product we have utilized python dialect as it is the most good with raspberry pi, additionally information pre-handling and web application advancement vaults are basic and proficient. As our cloud, we are utilizing administrations of MathWorks® ThingSpeak™ and adafruit IO.

The taking after figure portrays our model, the temperature and mugginess sensor hub, soil dampness sensor hub are hardwired into the raspberry pi. The ultimate python code is implanted in it as a tall need start-up daemon. As before long as you'll boot the raspberry pi the framework will begin working. The sensors hubs interfaces utilizing Standard Fringe Interface Transport (SPI) communicates commonly in a half-duplex way. The sensor hubs send information which is pre-processed employing a dynamic linear line and Number juggling cruel for mistake and commotion decrease. This can be at that point distributed to an Open Source IoT Cloud where information analytics will be performed (as appeared in taking after figures); at that point the cloud will send the information to the subscribed app utilizing publish/subscribe design.

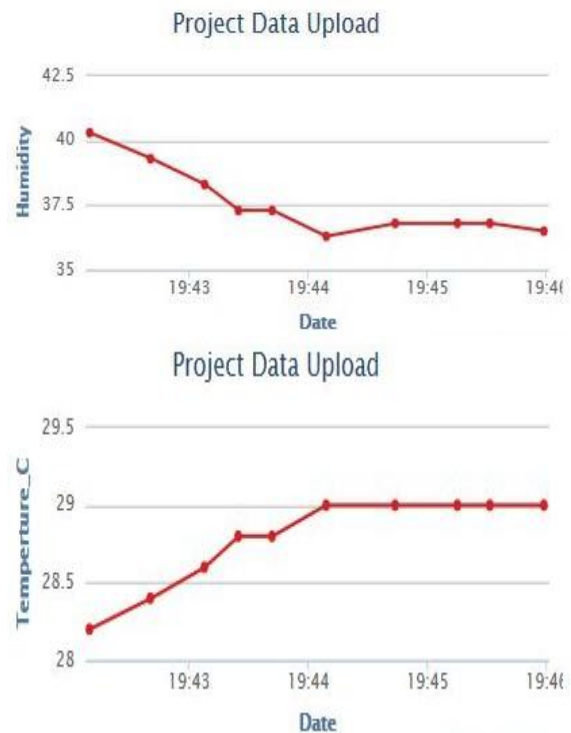

**Figure 9. Temperature Analytics Results**

There are three task methods of the atmosphere control framework; Time Based, Sensor Based, and User Based. In sensor based mode the exercises will be performed inside the nursery by means of introduced actuators, if the sensor peruses the temperature beneath the settled threshold. In a period based mode the exercises will be performed for a specific timeframe and on a specific interim as indicated by the client. Furthermore, in client based mode the exercises will be performed will be responsible for the client of the framework.

**VII. FUTURE WORK**

Here we have built up a working model which for needs to changed over to the item before introducing it into a genuine world, therefore our next undertaking is to change over it to an item. Additionally, information security is one of the significant issues in IoT-based frameworks in this

**VI. IMPLEMENTATION**

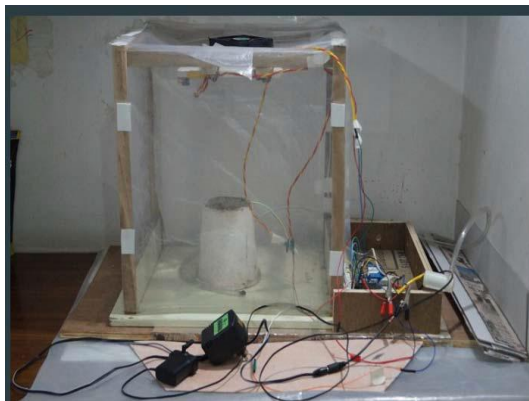

**Figure 8. Humidity Analytics Results**

way we will likewise enhance our model on this front.

### **VIII. CONCLUSION**

Our framework empowers individuals to screen and oversee developing states of their nursery. The utilization sensor hubs, web association, and the cloud will convey continuous updates about plants and help individuals develop plants all the more proficiently, with all perception and regular tests results presume that our undertaking will give an answer for robotizing nursery exercises and water system exercises. Execution of such a framework in the field can enhance the yield of the harvests and generally speaking creation, and with its quality to cost proportion, it will be reasonable to most of the farming network and furthermore to agro-based businesses.

### **IX. REFERENCES**

- [1] Dr. Ovidiu Vermesan; Dr. Peter Friess; "Internet of Things:Converging Technologies for Smart Environments and Integrated Ecosystems", River Publishers, Denmark, pp. 15, 2013.
- [2] Ji-Chun Zhao, Jun-Feng Zhang; Yu-Feng; Jian-Xin Guo "The Study and Application of the IOT Technology in Agriculture", 978-1-4244-55409/10/ 2010 IEEE.
- [3] Internet of Tomatoes: IoT in Agriculture – Explore IOT, <https://www.jigsawacademy.com/iot/blog/explore/internet-of-tomatoes-iot-in-agriculture/>.
- [4] Solutions for Smart Farming - Agriculture IoT Solutions and Internet of Things Technologies, <https://www.kaaproject.org/agriculture/>.
- [5] S. R. Nandurkar, V. R. Thool, R. C. Thool, "Design and Development of Precision Agriculture System Using Wireless Sensor Network", IEEE International Conference on Automation, Control, Energy and Systems (ACES), 2014.
- [6] F. daCosta, Rethinking the internet of things, A scalable approach to connecting everything, Apress, 2013.
- [7] Plantlink, <http://www.myplantlink.com/>.
- [8] Bitponics, <http://www.bitponics.com/>.
- [9] HarvestGeekBrains for your gardens, <http://www.kickstarter.com/>
- [10] Neel Pradip Shah, Prof. Priyang P. Bhatt, "Greenhouse Automation and Monitoring System - A survey", National Conference on Recent Advances in Computer Science and Technology (RACST), 2016.
- [11] Humidity Sensor: Types of Humidity Sensors & Working Principle,<https://www.engineersgarage.com/articles/humidity-sensor>.
- [12] Raspberry Pi - Teach, Learn, and Make with Raspberry Pi, <https://www.raspberrypi.org/>